

The given failure rates refer to more than one article.
For the valid articles please refer to the article list.

Device category 2 - electrical article with relay

Prediction done by: pykp03

at °C with % duty cycle based on Environmental condition MTTF in h MTTF in a failure rate in FIT (λ basis)

MTTF values and failure rates - relay contact -, details according to SN 29500-7

ambient temperature in °C	type of load	type of voltage	voltage in V	current in A	operating cycles per h	failure criteria	failure rate in FIT (λ contact)	MTTF in h	MTTF in a
40	resistive	DC	>0,5	<0,1	360	normal	360	2777777,78	317,1
40	resistive	AC	>13	>0,1	360	normal	36	2777777,78	3170,98
40	resistive	DC	>13	>0,1	360	normal	180	5555555,56	634,2
40	inductive	AC	>13	>0,1	360	normal	360	2777777,78	317,1
40	inductive	DC	>13	>0,1	360	normal	900	1111111,11	126,84
								-	-
								-	-
								-	-
								-	-
								-	-

Notes for device category 2 (electronic article with relay)

- failure rates (λ) respectively MTTF values (rounded)
- One changeover contact counts as two contact
- One double contact counts as one contact
- Optional spark-extinguished contacts behave like contacts on ohm resistive load at the same current load
- Standardized load characteristic diagrams are shown in diagramm

The failure rate respectively the MTTF value of the relay can be calculated with the following formula
Only used contacts have to be considered!

Calculation of total failure rate, λ device (FIT)

$$\lambda_{device} = \lambda_{basis} + \sum \lambda_{contact}$$

Calculation of total MTTF value, MTTF device (h)

$$MTTF_{device} = \frac{10^9 h}{\lambda_{device}}$$

Diagram

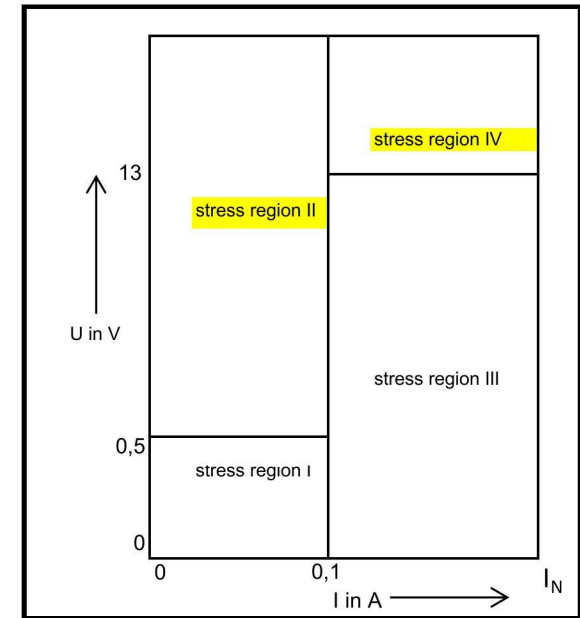

Example of a MTTF calculation for an electronic article with relay (e.g. relay modul)

1. Product

Relay module with 2 changeover contacts: PLC-RSC-24DC/21-21 (Art.-No. 2967060)



2. Application setup

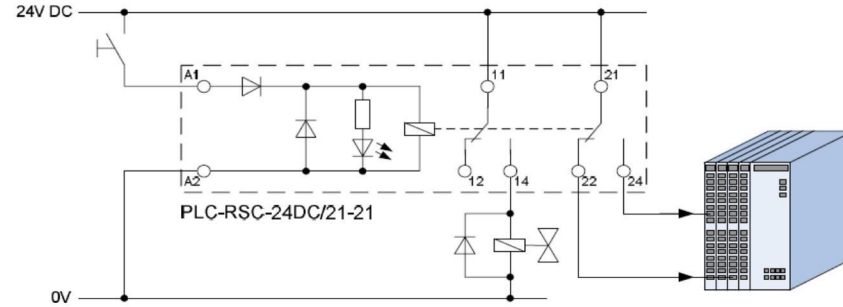

3. Information about contact load

Load 1 at contact 1 (only NC of the changeover contact is used):
Solenoid valve 24VDC / 1 A, wired up with freewheeling diode

Load 2 at contact 2 (change over contact is used):
Electronical control input, 24VDC / 10mA (resistive load)

4. Result lists of the failure rates λ

(relevant values for this example are highlighted in grey)

λ basic Failure rate for the electronic share (LED, freewheeling diode, polarity protection etc.) and e.g. the connections of the relay modul

λ contact Failure rate for one single contact of the relay module for different typical contact loads

Failure rate λ basic

at <input type="text" value="40"/> °C with <input type="text" value="100,00"/> % duty cycle	based on <input type="text" value="SN 29500"/>	Environmental condition <input type="text" value="GB, GC - Ground Benign, Controlled"/>	MTTF in h <input type="text" value="23310023,31"/>	MTTF in a <input type="text" value="2660,96"/>	failure rate in FIT (λ basis) <input type="text" value="42,9"/>
---	--	---	--	--	--

Failure rate λ contact

ambient temperature in °C	type of load	type of voltage	voltage in V	current in A	operating cycles per h	failure criteria	failure rate in FIT (λ contact)	MTTF in h	MTTF in a
40	resistive	DC	>0,5	<0,1	360	normal	360	2777777,78	317,1
40	resistive	AC	>13	>0,1	360	normal	36	27777777,78	3170,98
40	resistive	DC	>13	>0,1	360	normal	180	5555555,56	634,2
40	inductive	AC	>13	>0,1	360	normal	360	2777777,78	317,1
40	inductive	DC	>13	>0,1	360	normal	900	1111111,11	126,84

(1) A freewheeling diode at load 1 represent an ideal contact protection circuit at an inductive DC load and the inductive share of the load. -> Select value for resistive load!

5. Calculation of the MTTF for the whole relay modul

λ device = λ basic + $\sum \lambda$ contact -> in this example: -> λ device = λ basic + λ contact 1 + λ contact 2

Entry of the values from the result lists

$$\lambda_{device} = 42,9 \text{ FIT} + 180 \text{ FIT} + (2^{(2)} \times 360 \text{ FIT}) = 942,9 \text{ FIT}$$

(2) 2 x table value, because a changeover contact is considered as two contacts

$$MTTF_{device} = \frac{10^9 h}{\lambda_{device}} = \frac{10^9 h}{942,9} = 1060558 h = 121 \text{ years}$$

